

**CHERUBINI**

tocco italiano dal 1947



# PLUG & PLAY OCEAN EASY

Compact. Solid. Automatic!



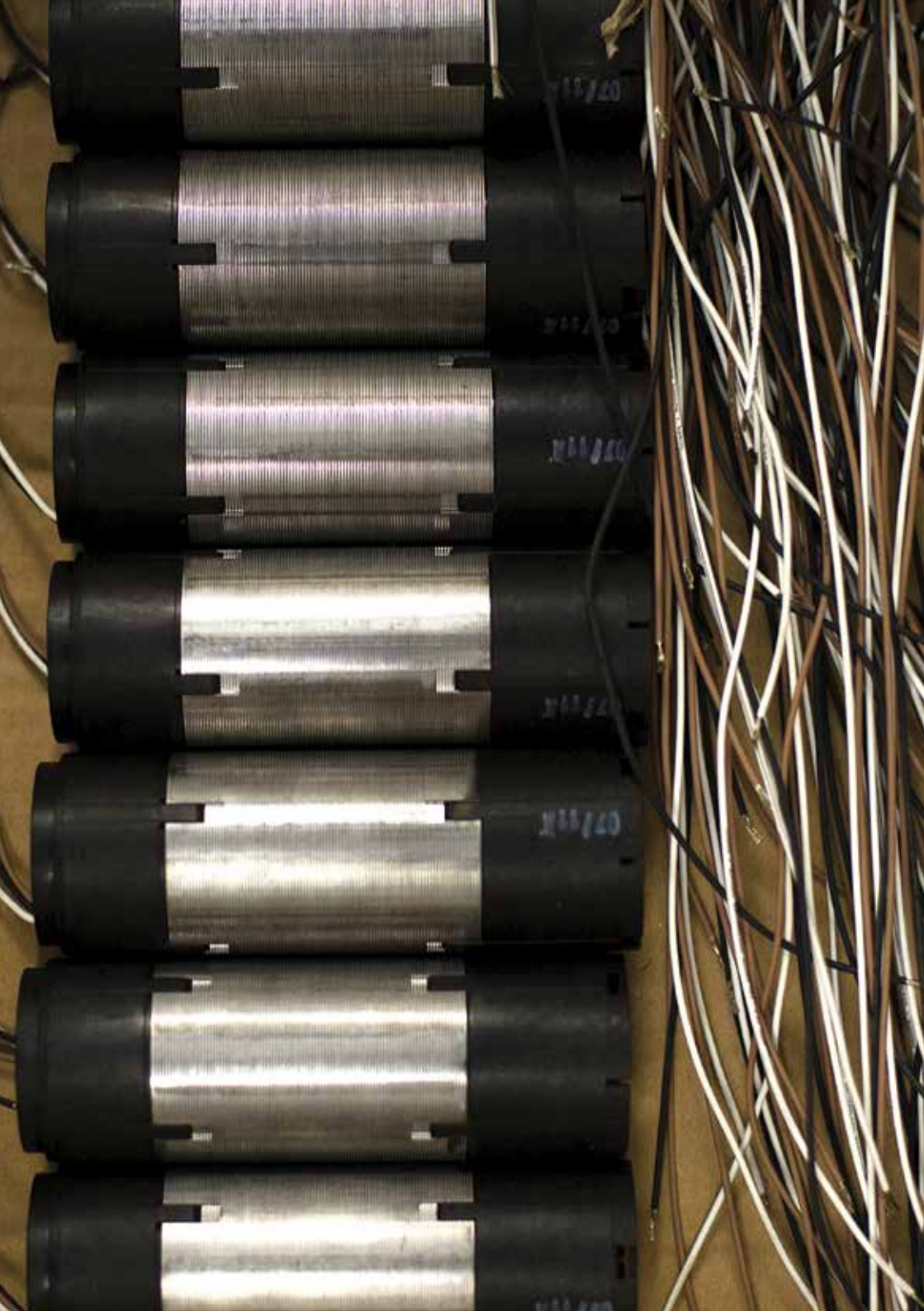



# Plug&Play Ocean Easy

Compact. Solid. Automatic!



- **Wired motor with electronic limit switch and override**  
Suitable for installation on blinds with rigid ribs and caps on the last blade.
- **Easy to install!**  
Insert the motor into the tube, connect it to the power supply and it's ready. No adjustment required.
- **Specific functions**
  - Automatic adjustment of the limit switches
  - After manual override, the end positions remain unchanged.
  - Obstacle detection when ascending and descending.
  - Suitable for connecting in parallel.
- **Automation of the motor with manual override device!**  
Combined with OPTime Easy control unit, the motor becomes a radio controlled motor and takes on these functions:
  - Obstacle detection sensitivity adjustable at 3 levels;
  - Two middle positions that are programmable and usable from the remote control.
- **Continuous self learning**  
Limit switches optimized by constant torque metering for the entire roller blind travel.
- **Protection against freezing**  
The motor will not operate if the guides and/or slats are frozen.
- **Compact override**  
Thanks to its small size, this device can be installed in limited spaces.  
Reduction ratio 1:18.
- **Fast installation**  
The connector system makes installation very fast and simple.

# Plug&Play Ocean Easy

## > Automatic adjustment of the limit switches

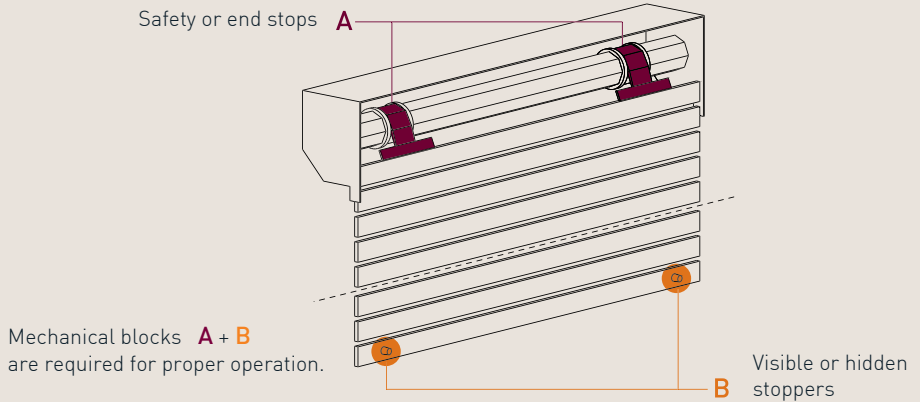

## > After manual override, the end positions remain unchanged

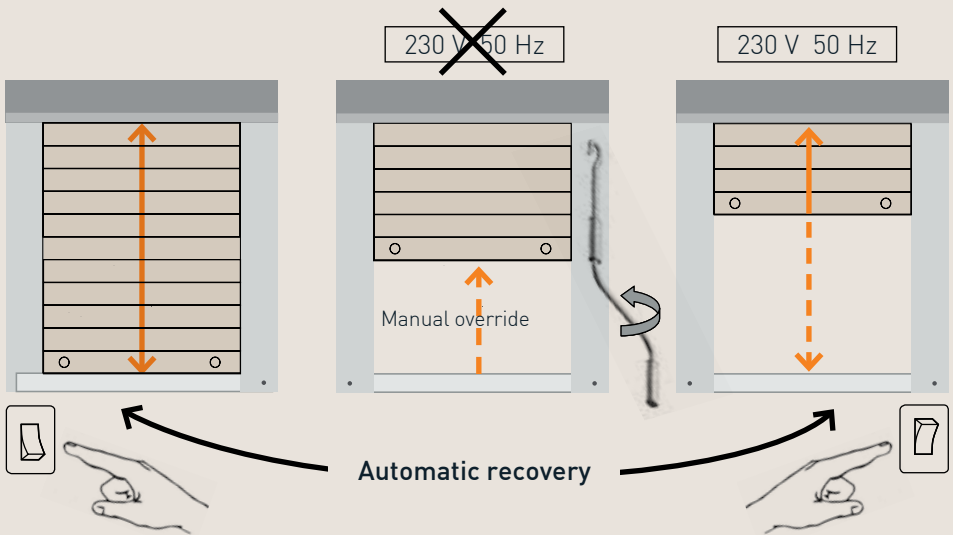

➤ Quick installation thanks to connector system

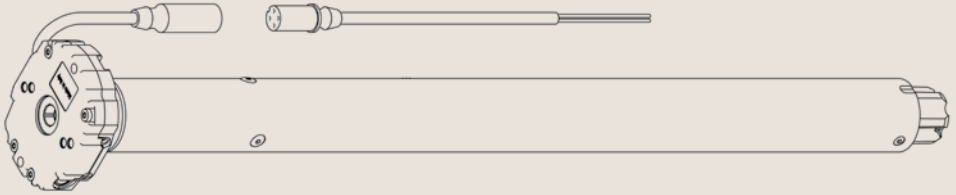

## Accessories for manual operation



- 1 ➤ **Folding crank with hook**  
length 150 cm.  
Ref. 7463 150G 210
- 2 ➤ **Eye with hexagon**  
7 × 86 mm.  
Ref. 6010 7008 CH16
- 3 ➤ **Magnetic joint.**  
Ref. 1498 7016 + 8056 M12
- 4 ➤ **Magnetic joint.**  
Ref. 1498 7016 + 8056 V13

# Plug&Play Ocean Easy

## Technical features

| Ø45                                     | AEN45101700 | AEN45201700 |
|---|-------------|-------------|
| Motor torque (Nm)                       | 10          | 20          |
| Speed (rpm)                             | 17          | 17          |
| Power (W)                               | 150         | 170         |
| Power supply (V/Hz)                     | 230/50      | 230/50      |
| Consumption (A)                         | 0.7         | 0.8         |
| Cable 4 x 0,75 (m) - connector included | l. 14 cm    | l. 14 cm    |
| Operating time (min)                    | 4           | 4           |
| Protection Grade                        | IP44        | IP44        |
| Weight (Kg)                             | 3,45        | 3,45        |
| L1 (mm)                                 | 646         | 646         |

The cable is supplied separately from the motor.

Choose the suitable length for the cable:

- A4503\_0333 Länge 1 m
- A4503\_0311 Länge 2 m
- A4503\_0314 Länge 4 m

## Dimensions

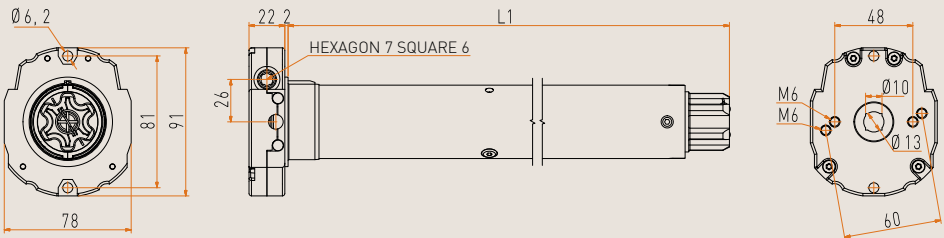

## Description

| Code        | Description                | Torque | Speed  |
|-------------|----------------------------|--------|--------|
| AEN45101700 | PLUG&PLAY OCEAN EASY 10/17 | 10 Nm  | 17 rpm |
| AEN45201700 | PLUG&PLAY OCEAN EASY 20/17 | 20 Nm  | 17 rpm |

## Compatible systems

Direct compatibility

Plug&Play Ocean Easy

A510023 Blue Bus

A510024 Blue Bus Rx

A510040 Optime Easy

A510027 / A510028 / A510029 Timer

## Compatible systems

Cross compatibility

Plug&Play Ocean Easy



Blue Bus RX

Optime Easy

All **Cherubini** remote controls

Domotic TX Transmitter

Domi

## Motor wire



# CHERUBINI

tocco italiano dal 1947

## CHERUBINI S.p.A.

Via Adige 55  
25081 Bedizzole (BS) / Italy  
Tel. +39 030 6872.039  
Fax +39 030 6872.040  
info@cherubini.it  
www.cherubini.it



## CHERUBINI France S.a.r.l.

ZI Du Mas Barbet  
165 Impasse Ampère  
30600 Vauvert / France  
Tel. +33 466 77 88 58  
Fax +33 466 77 92 32  
info@cherubini.fr  
www.cherubini.fr

## CHERUBINI Iberia S.L.

Avda.Uniòn Europea 11-H  
Apdo.283 - P.I. El Castillo  
03630 Sax. Alicante / Spain  
Tel. +34 966 967 504  
Fax +34 966 967 505  
info@cherubini.es  
www.cherubini.es

## CHERUBINI Deutschland GmbH

Siemensstrasse 40  
53121 Bonn / Germany  
Tel. +49 (0) 228 962 976 34 - 35  
Fax +49 (0) 228 962 976 36  
info@cherubini-group.de  
www.cherubini-group.de

## CHERUBINI DongGuan Ltd

Add.: No.4 Building,  
BaoMa Road - ShuiBian  
HengLi - DongGuan / China  
Tel. +86 (0) 769 8337 3981  
Fax +86 (0) 769 8337 2896  
info@cherubini.cn  
www.cherubini.it