

CHERUBINI
tocco italiano dal 1947

PLUG & PLAY PLUS

Innovation for versatility.

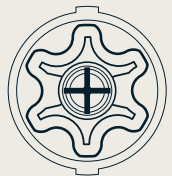



Plug&Play Plus

Innovation for versatility.



- **Electronic limit switch with wire control and encoder**
This motor is suitable for installation on blinds with both hard hangers and stoppers on the last blind.
- **Easy to install**
Insert the motor into the tube, connect it to the power supply and it's ready. When using lockers components no adjustment required.
- **Versatile**
Without lockers components upwards or downwards, one or both limit switches may be set on the external button panel.
DEDICATED BUTTON PANEL NOT REQUIRED!
- **Protection against freezing**
The motor will not operate if the guides and/or slats are frozen.
- **Specific functions**
Automatic adjustment of the limit switch.
Obstacle detection on both directions.
May be connected either directly or in parallel.
Direct attachment to the aluminium side without brackets (Ø 45, maximum 15 Nm).
- **Compatibility**
This motor is recommended as drive system for interior and exterior "monobloc" shutters, roller blinds and screens.
- **Available diameters**
Available in 35 and 45 mm versions covering a wide torque range from 5 to 50 Nm.

Plug&Play Plus

- > Direct attachment to the aluminium side without brackets (Ø 45, maximum 15 Nm).

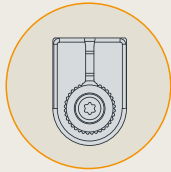
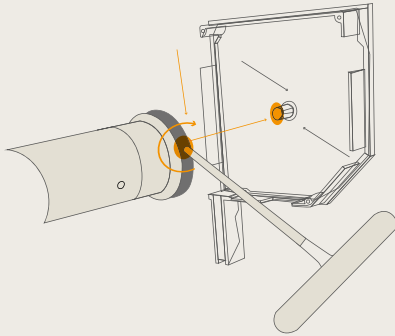

CLAMP

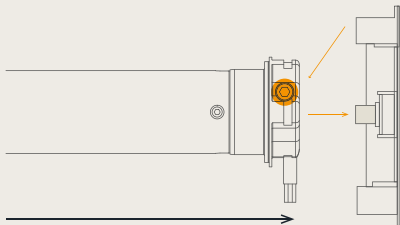

Plug&Play Plus

- > Lockers components required for automatic adjustment of the limit switches.

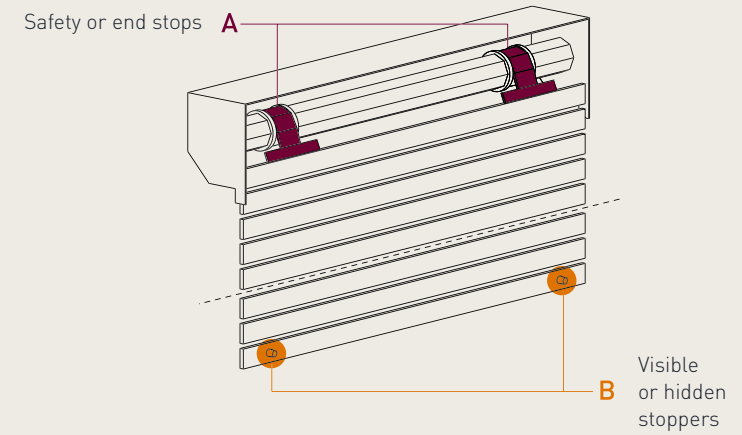

- > Suitable for connecting in parallel.

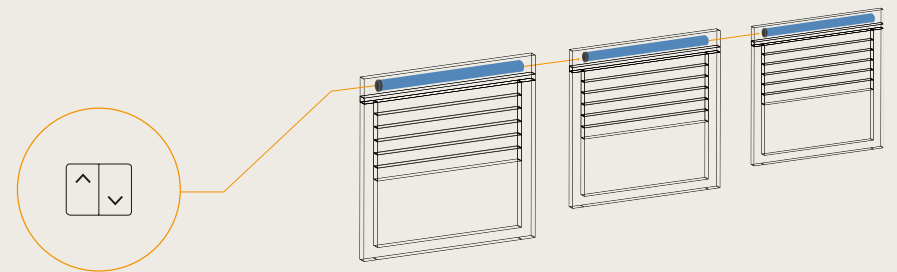

Plug&Play Plus

Main characteristics

Ø35

Code	Head	Torque	Speed	L (mm)	Certifications
AEQ35053000	Plastic material	5 Nm	30 rpm	547	CE
AEQ35091600	Plastic material	9 Nm	16 rpm	547	CE

Dimensions

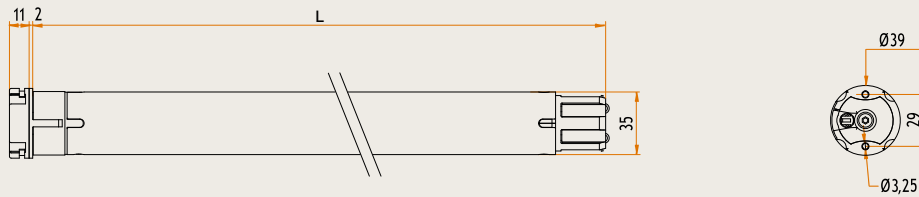

Ø45

Code	Head	Torque	Speed	L (mm)	Certifications
AEQ45061705	Plastic material with clamp	6 Nm	17 rpm	546	CE NF
AEQ45101705	Plastic material with clamp	10 Nm	17 rpm	546	CE NF
AEQ45151705	Plastic material with clamp	15 Nm	17 rpm	546	CE NF
AEQ45251705	Plastic material	25 Nm	17 rpm	586	CE NF
AEQ45321705	Plastic material	32 Nm	17 rpm	586	CE NF
AEQ45401705	Plastic material	40 Nm	17 rpm	586	CE NF
AEQ45501205	Plastic material	50 Nm	12 rpm	586	CE NF

Dimensions

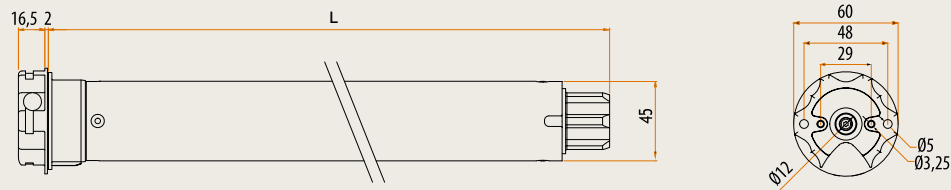

Plug&Play Plus

Compatible systems

Direct compatibility

Plug&Play Plus

A510023 Blue Bus

A510024 Blue Bus Rx

A510039 Optime / A510037 Compact Roll

A510036 Mini

A510027 / A510028 / A510029 Timer

Bluetooth® Home Automation System MAGO

Compatible systems

Cross compatibility

Plug&Play Plus



Blue Bus RX

Radio receiver

All Cherubini remote controls

Domotic TX Transmitter

Cable



CHERUBINI

tocco italiano dal 1947

CHERUBINI S.p.A.

Via Adige 55
25081 Bedizzole (BS) / Italy
Tel. +39 030 6872.039
Fax +39 030 6872.040
info@cherubini.it
www.cherubini.it

<http://www.linkedin.com/company/cherubini-spa>
<http://www.facebook.com/CherubiniSpa/>
<http://www.youtube.com/user/CherubiniSpa>



CHERUBINI France S.a.r.l.

ZI Du Mas Barbet
165 Impasse Ampère
30600 Vauvert / France
Tel. +33 466 77 88 58
Fax +33 466 77 92 32
info@cherubini.fr
www.cherubini.fr

CHERUBINI Iberia S.L.

Avda.Unión Europea 11-H
Apdo.283 - P.I. El Castillo
03630 Sax. Alicante / Spain
Tel. +34 966 967 504
Fax +34 966 967 505
info@cherubini.es
www.cherubini.es

CHERUBINI Deutschland GmbH

Siemensstrasse 40
53121 Bonn / Germany
Tel. +49 (0) 228 962 976 34 - 35
Fax +49 (0) 228 962 976 36
info@cherubini-group.de
www.cherubini-group.de

CHERUBINI DongGuan Ltd

Add.: No.4 Building,
BaoMa Road - ShuiBian
HengLi - DongGuan / China
Tel. +86 (0) 769 8337 3981
Fax +86 (0) 769 8337 2896
info@cherubini.cn
www.cherubini.it

CHERUBINI Türkiye

Ritim Istanbul
D-100 Güney Yanyolu
Cevizli Mahallesi, Zuhul Caddesi
34846 Maltepe - Istanbul / Turkey
Tel/Fax +90 (0) 216 515 6287
info@cherubini.com.tr
www.cherubini.com.tr